

SF-PHSL 2-100 S-VDE - Screwdriver



1212698

<https://www.phoenixcontact.com/au/products/1212698>

Please be informed that the data shown in this PDF document is generated from our Online Catalog. Please find the complete data in the user documentation. Our General Terms of Use for Downloads are valid.



Screwdriver, positive/negative PH slot, VDE insulated, size: PH 2 x 100, 2-component grip, with non-slip grip

Your advantages

- Screwdrivers for Phillips screws with Pozidriv and Phillips Recess screw head
- VDE approval

Commercial Data

Item number	1212698
Packing unit	10 pc
Minimum order quantity	10 pc
Sales Key	BG3146
Product Key	BH3146
Catalog Page	Page 447 (C-3-2019)
GTIN	4046356716611
Weight per Piece (including packing)	91.8 g
Weight per Piece (excluding packing)	91.8 g
Customs tariff number	82054000
Country of origin	CZ

SF-PHSL 2-100 S-VDE - Screwdriver



1212698

<https://www.phoenixcontact.com/au/products/1212698>

Technical Data

Notes

Environmental Product Compliance

California Proposition 65

Further information on California's prop. 65 is available under "Downloads" in the manufacturer's declaration

Product properties

Type

Phillips

Product type

Screwdriver tools

Connection data

Output

Phillips Recess/plus-minus

Dimensions

Dimensional drawing

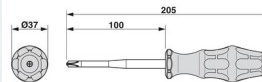

Width

37 mm

Blade width

6 mm

Blade height

100 mm

Length

205 mm

Wrench size

0 mm

Material specifications

Material

alloyed tool steel

Mounting

Wrench size

0 mm

SF-PHSL 2-100 S-VDE - Screwdriver



1212698

<https://www.phoenixcontact.com/au/products/1212698>

Drawings

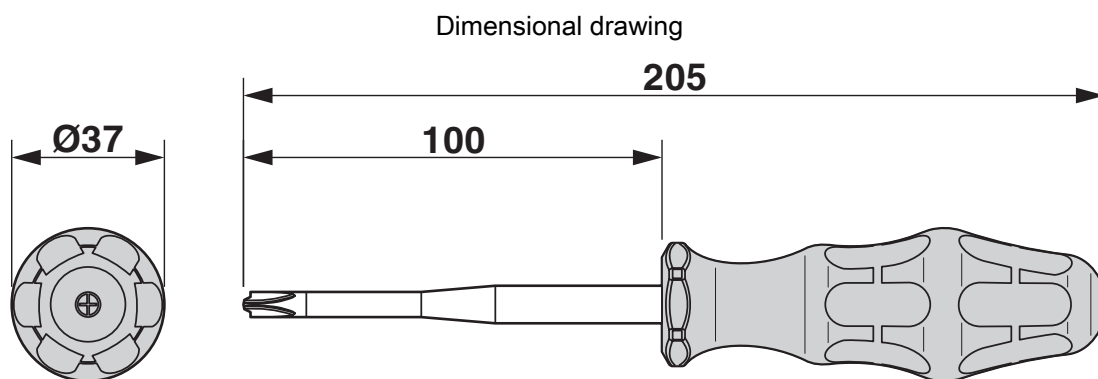

SF-PHSL 2-100 S-VDE - Screwdriver



1212698

<https://www.phoenixcontact.com/au/products/1212698>

Approvals



EAC

Approval ID: RU C-DE.AI30.B.01750



VDE Zeichengenehmigung

Approval ID: 40032921

SF-PHSL 2-100 S-VDE - Screwdriver



1212698

<https://www.phoenixcontact.com/au/products/1212698>

Classifications

ECLASS

ECLASS-10.0.1	21040406
ECLASS-11.0	21040406
ECLASS-12.0	21040406
ECLASS-13.0	21040406

ETIM

ETIM 8.0	EC000144
----------	----------

UNSPSC

UNSPSC 21.0	27111700
-------------	----------

Phoenix Contact 2023 © - all rights reserved
<https://www.phoenixcontact.com>

PHOENIX CONTACT PTY Ltd
Unit 7, 2-8 South Street
Rydalmere NSW 2116
1300 786 411
customerservice@phoenixcontact.com.au