

Power supply unit - TRIO-PS-2G/3AC/24DC/20 - 2903155

Please be informed that the data shown in this PDF Document is generated from our Online Catalog. Please find the complete data in the user's documentation. Our General Terms of Use for Downloads are valid (<http://phoenixcontact.com/download>)



Primary-switched TRIO POWER power supply with push-in connection for DIN rail mounting, input: 3-phase, output: 24 V DC/20 A

Product Description

TRIO POWER power supplies with standard functionality

The TRIO POWER power supply range with push-in connection has been perfected for use in machine building. All functions and the space-saving design of the single and three-phase modules are optimally tailored to the stringent requirements. Under challenging ambient conditions, the power supply units, which feature an extremely robust electrical and mechanical design, ensure the reliable supply of all loads.

Your advantages

- ✓ Save time and costs, thanks to the Push-in connection and narrow design
- ✓ Increase system availability, thanks to dynamic boost with 150% of the nominal current for five seconds
- ✓ Maximum flexibility due to the wide temperature range from -25°C to +70°C and device startup at -40°C
- ✓ Rugged design



Key Commercial Data

Packing unit	1 pc
GTIN	 4 046356 960861
GTIN	4046356960861
Weight per Piece (excluding packing)	1,717.000 g
Country of origin	China
Sales Key	CMPO33

Technical data

Dimensions

Width	65 mm
Height	130 mm
Depth	160 mm

Ambient conditions

Degree of protection	IP20
----------------------	------

Power supply unit - TRIO-PS-2G/3AC/24DC/20 - 2903155

Technical data

Ambient conditions

Ambient temperature (operation)	-25 °C ... 70 °C (> 60 °C Derating: 2.5 %/K)
Ambient temperature (start-up type tested)	-40 °C
Ambient temperature (storage/transport)	-40 °C ... 85 °C
Max. permissible relative humidity (operation)	≤ 95 % (at 25 °C, non-condensing)
Climatic class	3K3 (in acc. with EN 60721)
Degree of pollution	2
Installation height	≤ 5000 m (> 2000 m, Derating: 10 %/1000 m)

Input data

Nominal input voltage range	3x 400 V AC ... 500 V AC
	2x 400 V AC ... 500 V AC
Input voltage range	3x 400 V AC ... 500 V AC -20 % ... +15 %
	2x 400 V AC ... 500 V AC -10 % ... +15 %
AC frequency range	50 Hz ... 60 Hz
Discharge current to PE	< 3.5 mA
Current consumption	3x 1.2 A (400 V AC)
	3x 1 A (500 V AC)
	2x 2.3 A (400 V AC)
	2x 1.9 A (500 V AC)
Nominal power consumption	822.2 VA
Inrush current	≤ 22 A (typical)
Mains buffering time	typ. 10 ms (400 V AC)
	typ. 20 ms (500 V AC)
Input fuse	3.15 A (internal (device protection), slow-blow)
Recommended breaker for input protection	6 A ... 16 A (Characteristics B, C, D, K)
Power factor (cos phi)	0.63
Type of protection	Transient surge protection
Protective circuit/component	Varistor

Output data

Nominal output voltage	24 V DC ±1 %
Setting range of the output voltage (U_{Set})	24 V DC ... 28 V DC (> 24 V DC, constant capacity restricted)
Nominal output current (I_N)	20 A
Dynamic Boost ($I_{Dyn.Boost}$)	30 A (5 s)
Derating	> 60 °C ... 70 °C (2.5%/K)
Connection in parallel	Yes, for redundancy and increased capacity
Connection in series	yes
Protection against overvoltage at the output (OVP)	≤ 30 V DC
Control deviation	< 1 % (change in load, static 10 % ... 90 %)
	< 3 % (Dynamic load change 10 % ... 90 %, 10 Hz)
	< 0.1 % (change in input voltage ±10 %)

Power supply unit - TRIO-PS-2G/3AC/24DC/20 - 2903155

Technical data

Output data

Residual ripple	≤ 20 mV _{PP}
Output power	480 W
Typical response time	< 1 s
Maximum power dissipation in no-load condition	< 1.2 W (400 V AC)
Power loss nominal load max.	< 38 W (480 V AC)

General

Net weight	1.5 kg
Efficiency	> 93 % (400 V AC)
	500 V AC
Insulation voltage input/output	3 kV AC (type test)
	1.5 kV AC (routine test)
Protection class	I (in closed control cabinet)
Degree of protection	IP20
MTBF (IEC 61709, SN 29500)	> 1800000 h (25 °C)
	> 1100000 h (40 °C)
	> 510000 h (60 °C)
Mounting position	horizontal DIN rail NS 35, EN 60715
Assembly instructions	alignable: horizontally 0 mm (≤ 40 °C) 10 mm (≤ 70 °C), vertically 50 mm

Connection data, input

Connection method	Push-in connection
Conductor cross section solid min.	0.2 mm ²
Conductor cross section solid max.	4 mm ²
Conductor cross section flexible min.	0.2 mm ²
Conductor cross section flexible max.	2.5 mm ²
Conductor cross section AWG min.	24
Conductor cross section AWG max.	12
Stripping length	10 mm

Connection data, output

Connection method	Push-in connection
Conductor cross section solid min.	0.2 mm ²
Conductor cross section solid max.	10 mm ²
Conductor cross section flexible min.	0.2 mm ²
Conductor cross section flexible max.	6 mm ²
Conductor cross section AWG min.	24
Conductor cross section AWG max.	8
Stripping length	15 mm

Connection data for signaling

Connection method	Push-in connection
Conductor cross section solid min.	0.2 mm ²

Power supply unit - TRIO-PS-2G/3AC/24DC/20 - 2903155

Technical data

Connection data for signaling

Conductor cross section solid max.	1.5 mm ²
Conductor cross section flexible min.	0.2 mm ²
Conductor cross section flexible max.	1.5 mm ²
Conductor cross section AWG min.	24
Conductor cross section AWG max.	16
Stripping length	8 mm

Standards

EMC requirements for noise immunity	EN 61000-6-1
	EN 61000-6-2
EMC requirements for noise emission	EN 61000-6-3
	EN 61000-6-4
Standard - Safety of transformers	EN 61558-2-16 (air clearances and creepage distances only)
Standard - Electrical safety	IEC 60950-1/VDE 0805 (SELV)
Standard – Electronic equipment for use in electrical power installations and their assembly into electrical power installations	EN 50178/VDE 0160 (PELV)
Standard – Safety extra-low voltage	IEC 60950-1 (SELV) and EN 60204-1 (PELV)
Standard - Safe isolation	DIN VDE 0100-410
Standard – Limitation of mains harmonic currents	EN 61000-3-2
Rail applications	EN 50121-4

Conformance/approvals

UL approvals	UL Listed UL 508
	UL/C-UL Recognized UL 60950-1
Shipbuilding approval	GL applied for

EMC data

Electromagnetic compatibility	Conformance with EMC Directive 2014/30/EU
Low Voltage Directive	Conformance with Low Voltage Directive 2014/35/EC
Conducted noise emission	EN 55016
	EN 61000-6-3 (Class B)
Electrostatic discharge	EN 61000-4-2
Contact discharge	6 kV (Test Level 4)
Discharge in air	8 kV (Test Level 4)
Electromagnetic HF field	EN 61000-4-3
Frequency range	80 MHz ... 1 GHz
Test field strength	10 V/m (Test Level 3)
Frequency range	1 GHz ... 2 GHz
Test field strength	10 V/m (Test Level 3)
Frequency range	2 GHz ... 3 GHz
Test field strength	10 V/m (Test Level 3)
Comments	Criterion A
Fast transients (burst)	EN 61000-4-4

Power supply unit - TRIO-PS-2G/3AC/24DC/20 - 2903155

Technical data

EMC data

Input	4 kV (Test Level 4 - asymmetrical)
Output	2 kV (Test Level 3 - asymmetrical)
Signal	1 kV (Test Level 2 - asymmetrical)
Comments	Criterion A
Surge voltage load (surge)	EN 61000-4-5
Input	3 kV (Test Level 3 - symmetrical)
	6 kV (Test Level 4 - asymmetrical)
Output	1 kV (Test Level 2 - symmetrical)
	2 kV (Test Level 1 - asymmetrical)
Signal	1 kV (Test Level 1 - symmetrical)
Comments	Criterion B
Conducted interference	EN 61000-4-6
Frequency range	0.15 MHz ... 80 MHz
Voltage	10 V (Test Level 3)
Comments	Criterion A
Criterion A	Normal operating behavior within the specified limits.
Criterion B	Temporary impairment to operational behavior that is corrected by the device itself.

Environmental Product Compliance

REACH SVHC	Lead 7439-92-1
China RoHS	Environmentally Friendly Use Period = 25;
	For details about hazardous substances go to tab "Downloads", Category "Manufacturer's declaration"

Drawings

Block diagram

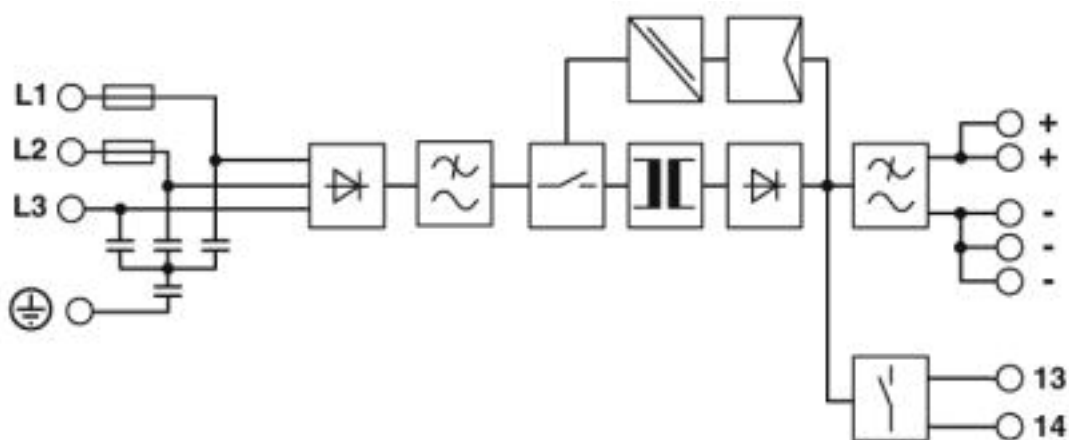

Power supply unit - TRIO-PS-2G/3AC/24DC/20 - 2903155

Classifications

eCl@ss

eCl@ss 4.0	27040700
eCl@ss 4.1	27040700
eCl@ss 5.0	27049000
eCl@ss 5.1	27049000
eCl@ss 6.0	27049000
eCl@ss 7.0	27049002
eCl@ss 8.0	27049002
eCl@ss 9.0	27040701

ETIM

ETIM 4.0	EC002540
ETIM 5.0	EC002540
ETIM 6.0	EC002540
ETIM 7.0	EC002540

UNSPSC

UNSPSC 13.2	39121004
UNSPSC 18.0	39121004
UNSPSC 19.0	39121004
UNSPSC 20.0	39121004
UNSPSC 21.0	39121004

Approvals

Approvals

Approvals

DNV GL / UL Listed / UL Recognized / cUL Recognized / IECCE CB Scheme / cUL Listed / EAC / cULus Recognized / cULus Listed

Ex Approvals

UL Listed / cUL Listed / cULus Listed

Approval details

DNV GL		https://approvalfinder.dnvgl.com/	TAA00000BM
--------	--	---	------------

Power supply unit - TRIO-PS-2G/3AC/24DC/20 - 2903155

Approvals

UL Listed		http://database.ul.com/cgi-bin/XYV/template/LISEXT/1FRAME/index.htm	FILE E 123528
-----------	--	---	---------------

UL Recognized		http://database.ul.com/cgi-bin/XYV/template/LISEXT/1FRAME/index.htm	FILE E 211944
---------------	--	---	---------------

cUL Recognized		http://database.ul.com/cgi-bin/XYV/template/LISEXT/1FRAME/index.htm	FILE E 211944
----------------	--	---	---------------

IECEE CB Scheme		http://www.iecee.org/	DK-44808-A1-UL
-----------------	--	---	----------------

cUL Listed		http://database.ul.com/cgi-bin/XYV/template/LISEXT/1FRAME/index.htm	FILE E 123528
------------	--	---	---------------

EAC			RU C- DE.A*30.B.01082
-----	--	--	--------------------------

cULus Recognized			
------------------	--	--	--

cULus Listed			
--------------	--	--	--

Accessories

Accessories

Device circuit breakers

Electronic device circuit breaker - CBM E4 24DC/0.5-10A NO-R - 2905743



Multi-channel, electronic device circuit breaker with active current limitation for protecting four loads at 24 V DC in the event of overload and short circuit. With nominal current assistant and electronic locking of the set nominal currents. For installation on DIN rails.

Power supply unit - TRIO-PS-2G/3AC/24DC/20 - 2903155

Accessories

Electronic device circuit breaker - CBM E8 24DC/0.5-10A NO-R - 2905744



Multi-channel, electronic device circuit breaker with active current limitation for protecting eight loads at 24 V DC in the event of overload and short circuit. With nominal current assistant and electronic locking of the set nominal currents. For installation on DIN rails.

Electronic device circuit breaker - CBMC E4 24DC/1-4A NO - 2906031



Multi-channel electronic device circuit breaker for protecting four loads at 24 V DC in the event of overload and short circuit. With electronic locking of the set nominal currents. For installation on DIN rails.

Electronic device circuit breaker - CBMC E4 24DC/1-10A NO - 2906032



Multi-channel electronic device circuit breaker for protecting four loads at 24 V DC in the event of overload and short circuit. With electronic locking of the set nominal currents. For installation on DIN rails.

Device protection

Type 3 surge protection device - PLT-SEC-T3-3S-230-FM - 2905230



Plug-in device protection, according to type 3/class III, for 3-phase power supply networks with separate N and PE (5-conductor system: L1, L2, L3, N, PE), with integrated surge-proof fuse and remote indication contact.

Type 3 surge protection device - PLT-SEC-T3-24-FM-PT - 2907925



Type 3 surge protection, consisting of protective plug and base element, with integrated status indicator and remote signaling for single-phase power supply networks. Nominal voltage 24 V AC/DC.

Potential distributor

Power supply unit - TRIO-PS-2G/3AC/24DC/20 - 2903155

Accessories

Potential distributors - VIP-2/SC/PDM-2/24 - 2315269



VARIOFACE module, with two equipotential busbars (P1, P2) for potential distribution, for mounting on NS 35 rails. Module width: 70.4 mm

Potential distributors - VIP-3/PT/PDM-2/24 - 2903798



VARIOFACE module with push-in connection and two equipotential busbars (P1, P2) for potential distribution, for mounting on NS 35 rails. Module width: 57.1 mm
