

TRIO-UPS-2G/1AC/24DC/10 - Uninterruptible power supply



2907161

<https://www.phoenixcontact.com/au/products/2907161>

Please be informed that the data shown in this PDF document is generated from our Online Catalog. Please find the complete data in the user documentation. Our General Terms of Use for Downloads are valid.



TRIO UPS - UPS with integrated power supply for lead AGM energy storage 1.2 Ah - 40 Ah, USB (Modbus/RTU), DIN rail mounting, Push-in connection, input: 1-phase, output: 24 V DC / 10 A

Product Description

Supply DC loads reliably and save space with the TRIO uninterruptible power supplies. An input grid is no longer necessary for startup. Connected industrial PCs can be shut down easily via the integrated USB interface.

Your advantages

- Space saving: Combination of UPS module and power supply in the same housing
- Long buffer times, thanks to large selection of VRLA energy storage systems
- USB interface for connection to higher-level controllers such as industrial PCs
- Startup from energy storage possible, even without mains input
- Universal range of possible applications, thanks to a comprehensive package of approvals and an extended temperature range
- Easy installation, thanks to push-in connection technology

Commercial Data

Item number	2907161
Packing unit	1 pc
Minimum order quantity	1 pc
Sales Key	CMUO13
Product Key	CMUO13
Catalog Page	Page 354 (C-4-2019)
GTIN	4055626166582
Weight per Piece (including packing)	1,637 g
Weight per Piece (excluding packing)	1,357 g
Customs tariff number	85044060
Country of origin	CN

TRIO-UPS-2G/1AC/24DC/10 - Uninterruptible power supply



2907161

<https://www.phoenixcontact.com/au/products/2907161>

Technical Data

Product properties

Product type	Uninterruptible power supply
Product family	TRIO UPS
MTBF (IEC 61709, SN 29500)	> 2007013 h (230 V AC, at 25 °C)
	> 1210518 h (230 V AC, at 40 °C)
	> 575978 h (230 V AC, at 60 °C)

Insulation characteristics

Protection class	I
Degree of pollution	2

Life expectancy (electrolytic capacitors)

Current	10 A
Temperature	40 °C
Time	73005 h
Additional text	230 V AC

Electrical properties

Number of phases	1.00
Insulation voltage input/output	4 kV AC (type test)
	2 kV AC (routine test)
Insulation voltage output / PE	500 V AC
	500 V AC (routine test)
Insulation voltage input / PE	3.5 kV AC (type test)
	2 kV AC (routine test)

Input data

Input voltage range	100 V AC ... 240 V AC -15 % ... +10 %
Voltage type of supply voltage	AC
Inrush current	< 9 A
Inrush current integral (I^2t)	< 0.2 A ² s
Frequency range (f_N)	50 Hz ... 60 Hz (± 10 %)
Mains buffering time	≥ 25 ms (120 V AC)
Switch-on time	typ. 200 ms
Typical current consumption	4.5 A (100 V AC)

Signal Bat.-Start

Connection labeling	3.6
Signalization designation	Bat.-Start
Low signal	Connection to SGnd with < 2.7 k Ω
High signal	Open (> 200 k Ω between Bat.-Start and SGnd)

Signal Remote

TRIO-UPS-2G/1AC/24DC/10 - Uninterruptible power supply



2907161

<https://www.phoenixcontact.com/au/products/2907161>

Connection labeling	3.5
Signalization designation	Remote
Low signal	Connection to SGnd with < 2.7 kΩ
High signal	Open (> 35 kΩ between Remote and SGnd)

Output data

Efficiency	typ. 90 % (120 V AC)
	typ. 91 % (230 V AC)
	typ. 96 % (Battery operation)
Derating	> 60 °C (2.5%/K of P _{Out} nom.)
Crest factor	1.5 (120 V AC)
	1.5 (230 V AC)
Switch-over time	< 20 ms
UPS connection in parallel	yes, with diode module uncoupled
UPS connection in series	no
Energy storage device connection in parallel	yes
Feedback voltage resistance	≤ 35 V DC
Protection against overvoltage at the output (OVP)	< 30 V DC
Residual ripple	< 20 mV
Control deviation	< 0.55 % (change in load, static 10 % ... 90 %)
	< 2.6 % (Dynamic load change 10 % ... 90 %, 10 Hz)
	< 0.05 % (change in input voltage ±10 %)
Rise time	< 30 ms
Permissible backup fuse	B10

Mains operation

Output voltage	24 V DC
Output voltage range	24 V DC ... 28 V DC (> 24 V constant capacity)
Output current I _N	10 A
Dynamic Boost (I _{Dyn.Boost})	15 A
Output power P _{OUT} (U _N , I _{OUT} = I _N)	240 W
Maximum no-load power dissipation	< 3 W (230 V AC)
Power loss nominal load max.	< 32 W (230 V AC)

Battery operation

Output voltage	U _{BAT} -0.1 V DC
Output voltage range	18 V DC ... 30 V DC
Output current I _N	10 A
Dynamic Boost (I _{Dyn.Boost})	15 A

Signal Alarm

Connection labeling	3.2
Signalization designation	Alarm
Type of signaling	LED red
Switching output	Transistor output, active

TRIO-UPS-2G/1AC/24DC/10 - Uninterruptible power supply



2907161

<https://www.phoenixcontact.com/au/products/2907161>

Output voltage	24 V DC
Continuous load current	20 mA
LED status indicator	red

Signal Battery mode

Connection labeling	3.3
Signalization designation	Battery mode
Type of signaling	Yellow LED
Switching output	Transistor output, active
Output voltage	24 V DC
Continuous load current	20 mA
LED status indicator	yellow

Signal DC OK

Connection labeling	3.1
Signalization designation	DC OK
Type of signaling	Green LED
Switching output	Transistor output, active
Output voltage	24 V DC
Continuous load current	20 mA
LED status indicator	green

Signal Ready

Connection labeling	3.4
Signalization designation	Ready
Switching output	Transistor output, active
Output voltage	24 V DC
Continuous load current	20 mA

Energy storage

Nominal voltage U_N	24 V DC
End-of-charge voltage	max. 30 V DC
Nominal capacity (without additional charger)	1.2 Ah ... 40 Ah
Battery technology	VRLA-AGM
Charge characteristic curve	IU_0U

Interfaces

Interface	USB (Modbus/RTU)
Number of interfaces	1
Connection method	MINI-USB Type B
Locking	Screw

Dimensions

Width	68 mm
Height	130 mm
Depth	160 mm

TRIO-UPS-2G/1AC/24DC/10 - Uninterruptible power supply



2907161

<https://www.phoenixcontact.com/au/products/2907161>

Installation dimensions

Installation distance right/left	0 mm / 0 mm
Installation distance top/bottom	50 mm / 50 mm

Alternative assembly

Width	160 mm
Height	130 mm
Depth	68 mm

Material specifications

Flammability rating according to UL 94 (housing / terminal blocks)	V0
Housing material	Metal
Hood version	PC
Side element version	Aluminum

Environmental and real-life conditions

Ambient conditions

Degree of protection	IP20
Ambient temperature (operation)	-25 °C ... 70 °C (> 60 °C Derating: 2,5 %/K)
Ambient temperature (storage/transport)	-40 °C ... 85 °C
Ambient temperature (start-up type tested)	-40 °C
Maximum altitude	≤ 4000 m (> 2000 m, observe derating)
Climatic class	3K3 (in acc. with EN 60721)
Max. permissible relative humidity (operation)	≤ 93 % (At +25°C, non-condensing)
Shock	30g, 18 ms according to IEC 60068-2-27
Vibration (operation)	< 12 ... 13.2 Hz, amplitude ±1 mm, 13.2 ... 100 Hz, 0.7g in accordance with IEC 60068-2-6

Approval data

UL

Identification	UL Listed UL 61010
----------------	--------------------

UL

Identification	UL/C-UL Listed ANSI/ISA-12.12.01 Class I, Division 2, Groups A, B, C
----------------	----------------------------------------------------------------------

Shipbuilding

Identification	DNV
----------------	-----

Shipbuilding

Identification	LR
----------------	----

EMC data

Low Voltage Directive	Conformance with Low Voltage Directive 2014/35/EC
EMC requirements for noise emission	EN 61000-6-3

TRIO-UPS-2G/1AC/24DC/10 - Uninterruptible power supply



2907161

<https://www.phoenixcontact.com/au/products/2907161>

	EN 61000-6-4
EMC requirements for noise immunity	EN 61000-6-1
	EN 61000-6-2
	Immunity in accordance with EN 61000-6-2 (industrial)
Noise immunity	Immunity in accordance with EN 61000-6-2 (industrial)
Electromagnetic compatibility	Conformance with EMC Directive 2014/30/EU
Conducted noise emission	EN 61000-6-3
Noise emission	EN 61000-6-3
DNV GL conducted interference	Class B
Additional text	Area power distribution
DNV GL noise radiation	Class B
Additional text	Bridge and deck area

Harmonic currents

Standards/regulations	EN 61000-3-2
-----------------------	--------------

Flicker

Standards/regulations	EN 61000-3-3
-----------------------	--------------

Electrostatic discharge

Standards/regulations	EN 61000-4-2
-----------------------	--------------

Electrostatic discharge

Contact discharge	6 kV (Test Level 3)
Discharge in air	8 kV (Test Level 3)

Electromagnetic HF field

Standards/regulations	EN 61000-4-3
-----------------------	--------------

Electromagnetic HF field

Frequency range	80 MHz ... 6 GHz
Test field strength	10 V/m
Frequency range	1.4 GHz ... 6 GHz
Test field strength	3 V/m

Fast transients (burst)

Standards/regulations	EN 61000-4-4
-----------------------	--------------

Fast transients (burst)

Input	4 kV
Output	2 kV
Signal	2 kV

Surge voltage load (surge)

Standards/regulations	EN 61000-4-5
Input	2 kV (Test Level 4 - symmetrical)
	4 kV (Test Level 4 - asymmetrical)
Output	1 kV (Test Level 3 - symmetrical)
	2 kV (Test Level 3 - asymmetrical)

TRIO-UPS-2G/1AC/24DC/10 - Uninterruptible power supply



2907161

<https://www.phoenixcontact.com/au/products/2907161>

Signal	1 kV (Test Level 2 - asymmetrical)
Conducted interference	
Standards/regulations	EN 61000-4-6
Conducted interference	
Frequency range	0.15 MHz ... 80 MHz
Voltage	10 V
Attenuated sinusoidal oscillations (ring wave)	
Standards/regulations	EN 61000-4-12
Comments	Criterion A

Standards and regulations

Overvoltage category	
EN 61010-1	II
Safety for measurement, control, and laboratory equipment	
Standards/specifications	IEC 61010-1
Protective extra-low voltage	
Standards/specifications	IEC 61010 (SELV) / (PELV)
Safe isolation	
Standards/specifications	DIN VDE 0100-410
Low-voltage power supplies, DC output	
Standards/specifications	EN 61204-3
Ship's bridge	
Standards/specifications	IEC/EN 60945

Mounting

Mounting type	DIN rail mounting
Assembly instructions	alignable: horizontally 0 mm, vertically 50 mm
Mounting position	horizontal DIN rail NS 35, EN 60715

2907161

<https://www.phoenixcontact.com/au/products/2907161>

Drawings

Schematic diagram

Housing

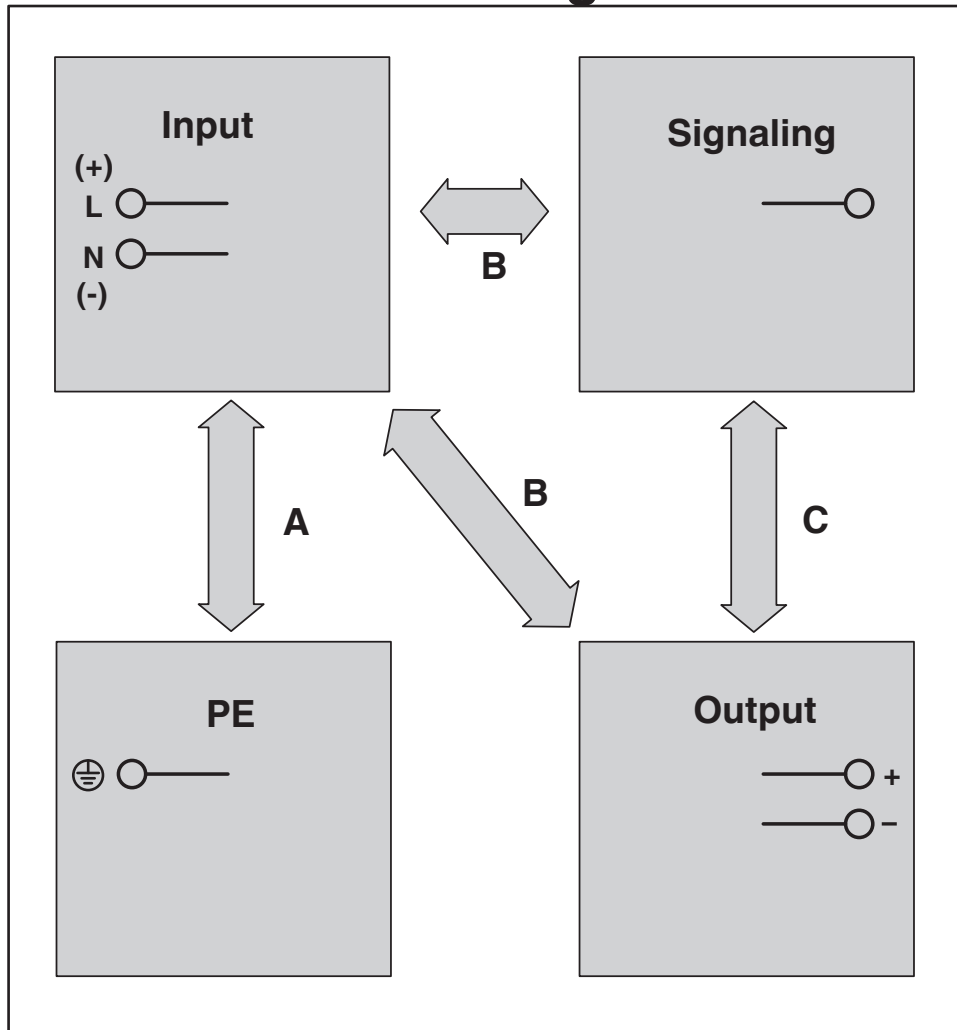

TRIO-UPS-2G/1AC/24DC/10 - Uninterruptible power supply



2907161

<https://www.phoenixcontact.com/au/products/2907161>

Block diagram

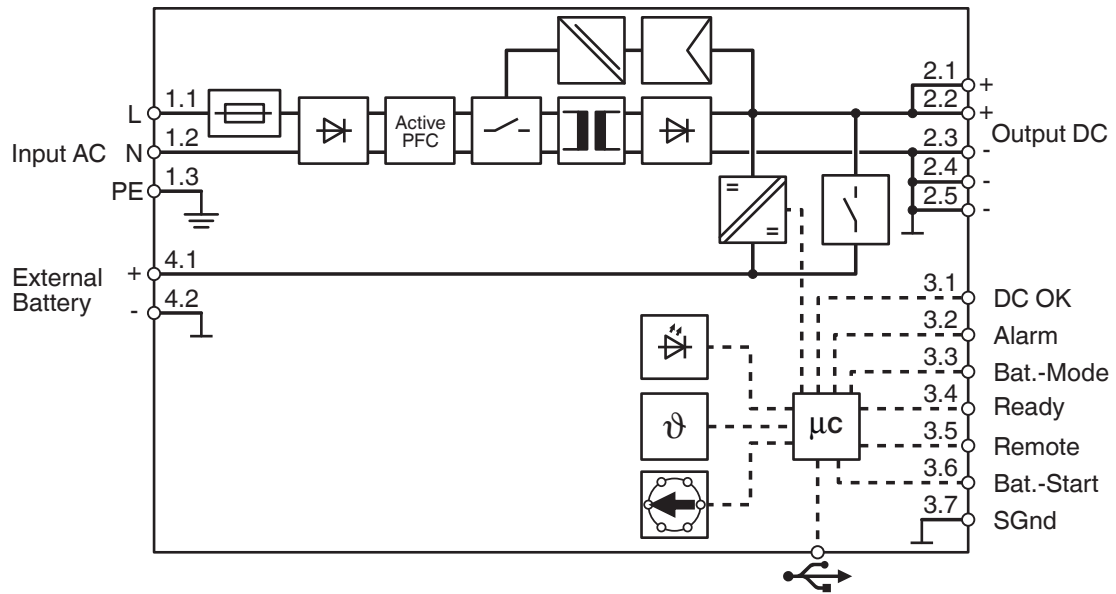

TRIO-UPS-2G/1AC/24DC/10 - Uninterruptible power supply



2907161

<https://www.phoenixcontact.com/au/products/2907161>

Approvals



IECEE CB Scheme

Approval ID: DK-67494-UL



EAC

Approval ID: RU S-DE.BL08.W.00764



LR

Approval ID: LR2002877TA



EAC

Approval ID: RU-DE.B.00184/20



UL Listed

Approval ID: FILE E 123528



cUL Listed

Approval ID: FILE E 123528



KC

Approval ID: R-R-PCK-2907160



cUL Listed

Approval ID: FILE E 199827



UL Listed

Approval ID: FILE E 199827

TRIO-UPS-2G/1AC/24DC/10 - Uninterruptible power supply



2907161

<https://www.phoenixcontact.com/au/products/2907161>

Classifications

ECLASS

ECLASS-11.0	27040705
ECLASS-13.0	27040705
ECLASS-12.0	27040705

ETIM

ETIM 8.0	EC000382
----------	----------

UNSPSC

UNSPSC 21.0	39121000
-------------	----------

TRIO-UPS-2G/1AC/24DC/10 - Uninterruptible power supply



2907161

<https://www.phoenixcontact.com/au/products/2907161>

Environmental Product Compliance

REACH SVHC	Lead 7439-92-1
China RoHS	Environmentally Friendly Use Period = 25;
	For information on hazardous substances, refer to the manufacturer's declaration available under "Downloads"

TRIO-UPS-2G/1AC/24DC/10 - Uninterruptible power supply



2907161

<https://www.phoenixcontact.com/au/products/2907161>

Accessories

UPS-BAT/PB/24DC/1.2AH - Energy storage

1274520

<https://www.phoenixcontact.com/au/products/1274520>



Energy storage, VRLA-AGM, 24 V DC, 1.2 Ah, automatic detection and communication with QUINT UPS-IQ

UPS-BAT/PB/24DC/4AH - Energy storage

1274117

<https://www.phoenixcontact.com/au/products/1274117>



Energy storage, VRLA-AGM, 24 V DC, 4 Ah, automatic detection and communication with QUINT UPS-IQ

TRIO-UPS-2G/1AC/24DC/10 - Uninterruptible power supply



2907161

<https://www.phoenixcontact.com/au/products/2907161>

UPS-BAT/PB/24DC/7AH - Energy storage

1274118

<https://www.phoenixcontact.com/au/products/1274118>



Energy storage, VRLA-AGM, 24 V DC, 7 Ah, automatic detection and communication with QUINT UPS-IQ

UPS-BAT/PB/24DC/12AH - Energy storage

1274119

<https://www.phoenixcontact.com/au/products/1274119>



Energy storage, VRLA-AGM, 24 V DC, 12 Ah, automatic detection and communication with QUINT UPS-IQ

TRIO-UPS-2G/1AC/24DC/10 - Uninterruptible power supply



2907161

<https://www.phoenixcontact.com/au/products/2907161>

UPS-BAT/PB/24DC/20AH - Energy storage

1348516

<https://www.phoenixcontact.com/au/products/1348516>



Energy storage, VRLA-AGM, 24 V DC, 20 Ah, automatic detection and communication with QUINT UPS-IQ

UPS-BAT/PB/24DC/40AH - Energy storage

1354641

<https://www.phoenixcontact.com/au/products/1354641>



Energy storage, VRLA-AGM, 24 V DC, 40 Ah, automatic detection and communication with QUINT UPS-IQ

TRIO-UPS-2G/1AC/24DC/10 - Uninterruptible power supply



2907161

<https://www.phoenixcontact.com/au/products/2907161>

UPS-BAT/VRLA-WTR/24DC/13AH - Energy storage

2320416

<https://www.phoenixcontact.com/au/products/2320416>



Energy storage device, lead AGM, VRLA technology, 24 V DC, 13 Ah, tool-free battery replacement, automatic detection, and communication with QUINT UPS-IQ

UPS-BAT/VRLA-WTR/24DC/26AH - Energy storage

2320429

<https://www.phoenixcontact.com/au/products/2320429>



Energy storage device, lead AGM, VRLA technology, 24 V DC, 26 Ah, tool-free battery replacement, automatic detection, and communication with QUINT UPS-IQ

TRIO-UPS-2G/1AC/24DC/10 - Uninterruptible power supply



2907161

<https://www.phoenixcontact.com/au/products/2907161>

MINI-SCREW-USB-DATACABLE - Data cable

2908217

<https://www.phoenixcontact.com/au/products/2908217>



Used for communication between an industrial PC and Phoenix Contact devices with USB-Mini-B connection.

UWA 130 - Mounting adapter

2901664

<https://www.phoenixcontact.com/au/products/2901664>



2-piece universal wall adapter for securely mounting the device in the event of strong vibrations. The profiles that are screwed onto the side of the device are screwed directly onto the mounting surface. The universal wall adapter is attached on the left/right.

TRIO-UPS-2G/1AC/24DC/10 - Uninterruptible power supply



2907161

<https://www.phoenixcontact.com/au/products/2907161>

UWA 182/52 - Mounting adapter

2938235

<https://www.phoenixcontact.com/au/products/2938235>



Universal wall adapter for securely mounting the device in the event of strong vibrations. The device is screwed directly onto the mounting surface. The universal wall adapter is attached on the top/bottom.

Phoenix Contact 2023 © - all rights reserved

<https://www.phoenixcontact.com>

PHOENIX CONTACT PTY Ltd

Unit 7, 2-8 South Street

Rydalmere NSW 2116

1300 786 411

customerservice@phoenixcontact.com.au